

# TECHNICAL WHITE PAPER



## Eliminate Artifact Lines With Consistent Linear Motion

### Contents

- Introduction
- Basics of Linear Slide Accuracy
- Comparison of Basic Slide Options
- Inspection Reports & Analysis of Slide Systems Accuracy
- Factors Contributing to Consistent Torque
- Summary



### - Introduction

The use of large format digital image scanning has broadened into many fields such as architectural drawings, mapping, and medical x-rays to name a few. Output devices such as ink jet printers and plotters are continuing to increase in resolution and size for creating posters, billboards, signs, and many other various applications. In all these areas, the need for clean scans and output without the distraction and interference of artifact lines is critical. For example, a doctor's misread x-ray because of poor quality could ultimately prove fatal. At the center of many of these systems is a linear motion device that controls the scanning motion. Consistency in this motion is the essential factor in developing a successful scanner design.

There are two major factors that come into play when producing consistency in linear motion for imaging applications.

1. Positional accuracy vs. repeatability
2. Equally applied torque

Ultimately these items work hand-in-hand to produce consistent output, but by breaking each one down to its individual elements, a full analysis of the entire system can be evaluated. The best basis for building that understanding is to review the basic terms and principles associated with linear accuracy and how it is measured.

## - Basics of Linear Slide Accuracy:

1. Positional accuracy - the variation between a slides desired position and its actual position. This covers position in any plane or direction, not just linear position on the slide. (See Figure #1 for more detail.)
2. Repeatability - the variation between a slides first movement to a position and its subsequent movements to the same position. This can be in either one direction (unidirectional) or both directions (bi-directional).

Variations in the movement of the carriage and its ability to repeat those movements will always be present to some extent. These variations can be from end-to-end (pitch), side-to-side (roll), or twisting moments (yaw).

The amount of error in a linear slide can be traced back through the manufacturing process of the individual components. Each is manufactured within its own tolerance range, but the more components required, the greater the combined tolerance or margin for error that is inherently built into the final product. In other words, inaccuracy is designed in from the very beginning.

In the case of imaging, scanning or output applications, the resulting excessive and unpredictable variations in the movement of the slides carriage will result in artifact lines on the output. Therefore it is critical to control the amount of variance built into the base components.

Figure #1

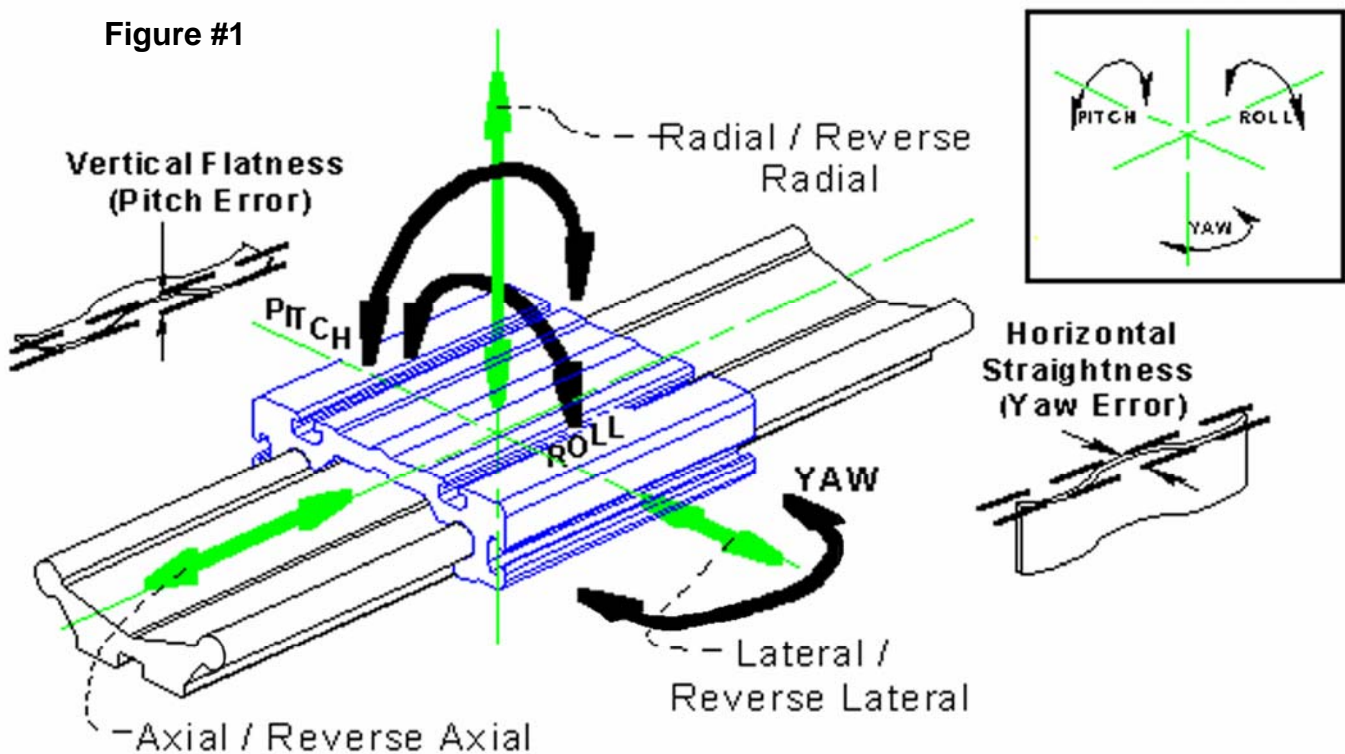

## - Comparison of Slide Options:

### 1. Traditional component build-up

Components include:

- a. Bearing shell
- b. Balls
- c. Raceways
- d. Seals
- e. Anti-rotation pins
- f. Retaining rings
- g. Shafting
- h. Mounting bolts
- i. Base rail
- j. Carriage housing

*NOTE: For an average 32" stroke system, approximately 300 individual components are required.*

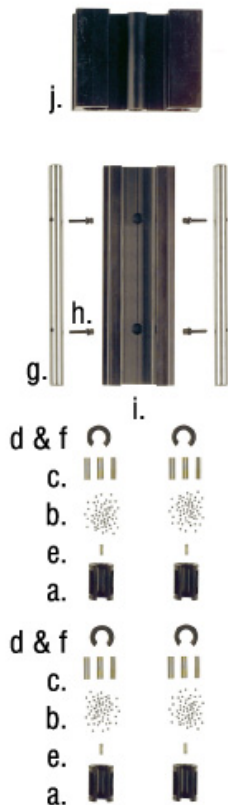

### 2. 2-Piece Uni-Guide

Components include:

- a. 1-piece carriage with bearing surface molecularly bonded directly to the aluminum substrate.
- b. 1-piece rail manufactured with a proprietary sizing process and finished with a RC70 ceramic coating.



Base slide is composed of two pieces – rail and carriage

RC70 ceramic finish on the rail surface

FrelonGOLD self-lubricating bearing material is molecularly bonded directly to the carriage

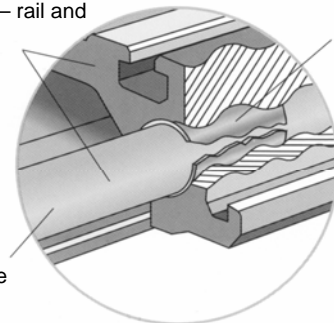

It is true that in the first type of slide (built up from components), much of the tolerance stack up can be taken out of the equation by applying “preload” or over tightening the assembly to remove play between components. However, more often than not, this preload will cause the unit to twist or warp resulting in greater variance in motion. In addition, preload will reduce the life expectancy of the rolling elements and raceways resulting in premature failures.

A comparison of the dimensional variations in these two types of guide rails is made in the inspection reports on the next two pages.

## Rail Inspection Report & Analysis

Specimens: assembled components for dual rail, rolling element linear guidance system

Overall Rail Length: 32"

Number of Components: 15

Inspection Method: Set theoretical zero at the beginning of the rail. Check rail location at 2" intervals.

NOTE: Dimensions shown are the averages based on the inspection of various assembled systems.

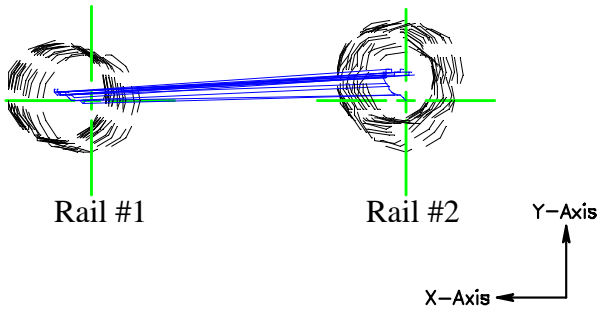

## X-Axis Deviation (Horizontal Straightness or Yaw Error)

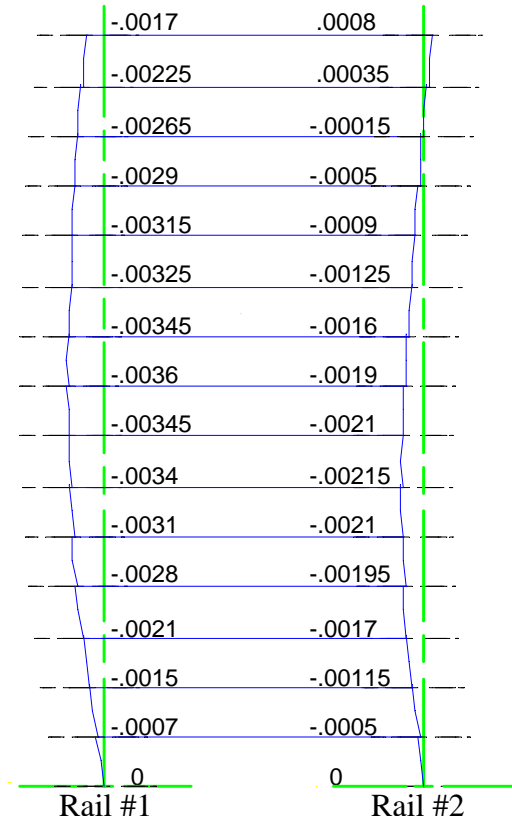

## Y-Axis Deviation (Vertical Flatness or Pitch Error)

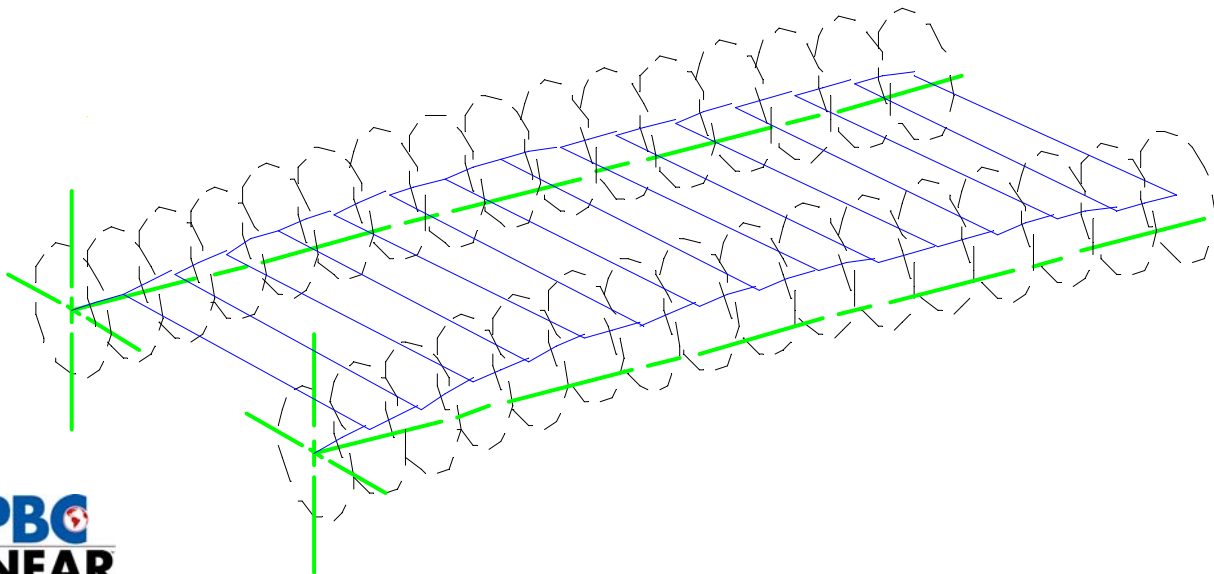
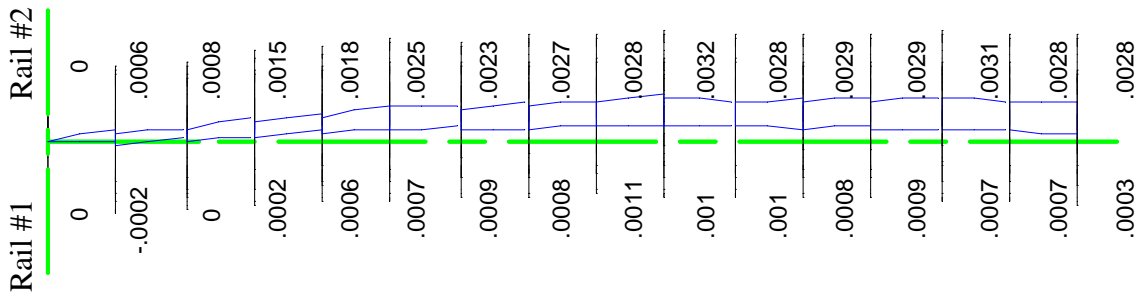

## Rail Inspection Report & Analysis

Specimens: 1-piece extruded rail with ceramic finish  
(Uniguide from PBC Linear , Roscoe, IL.)

Overall Rail Length: 32"

Number of Components: 1

Inspection Method: Set theoretical zero at the beginning of the rail. Check rail location at 2" intervals.

NOTE: Dimensions shown are averages based on the inspection of 5 different rails.

## X-Axis Deviation (Horizontal Straightness or Yaw Error)

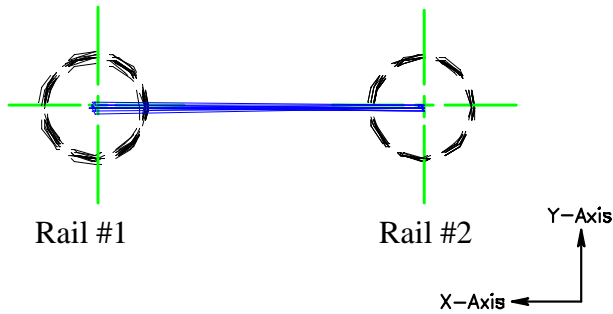
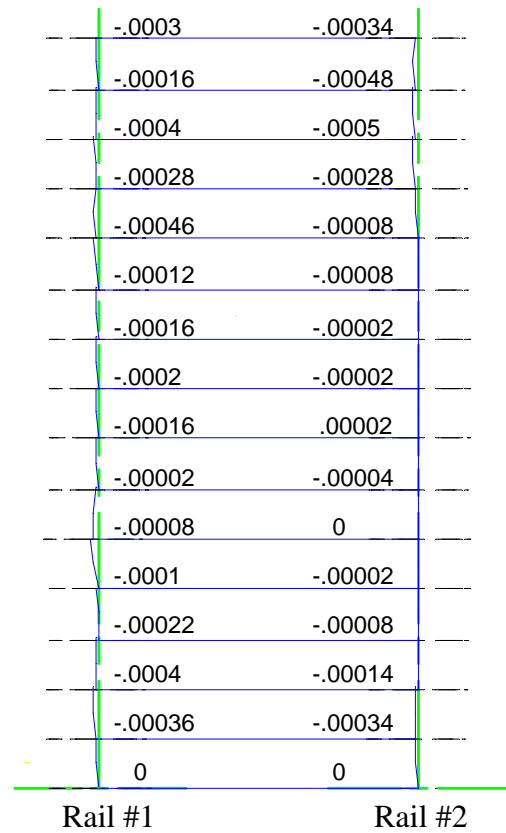

## Y-Axis Deviation (Vertical Flatness or Pitch Error)

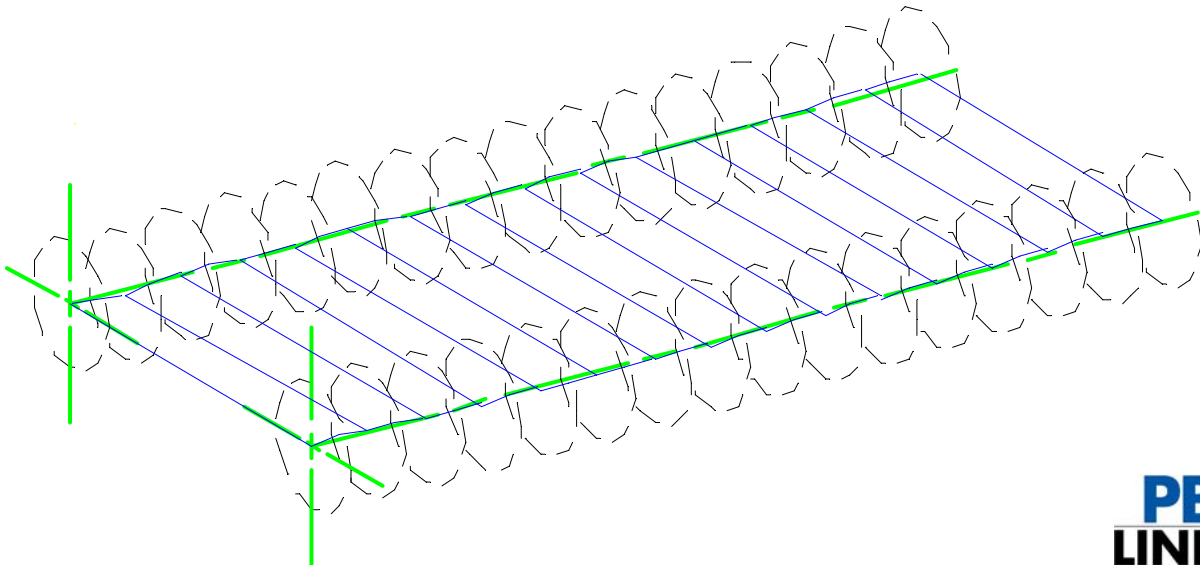
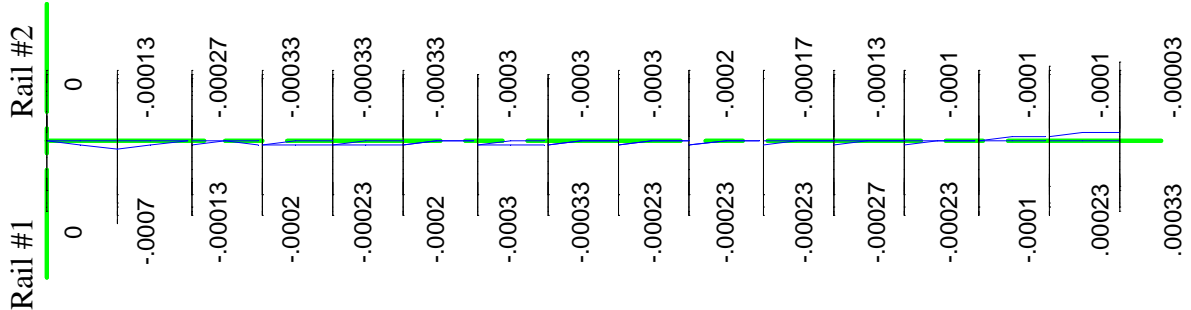

## - Factors Contributing to Consistent Torque:

Once a slides dimensional accuracy and repeatability are assured, the consistency of torque required to drive that slide becomes the next hurdle in regularly producing good images. Variations in torque can be caused by a wide variety of ingredients within the system. These can include, but are not limited to the surface finish of the rails, type of lubrication, the type of drive mechanism selected (lead screw, ball screw, etc.), types of support bearings used on the drive mechanism (ball, angular contact, etc.), cage creep in rolling elements, connection of the drive mechanism to the carriage, type of motor, coupling to the motor, and so on.

For this comparison, we will consider that all other factors are equal outside of the base slide system; the type of linear guide bearing then becomes key in contributing to consistent torque.

The two types of bearings utilized, are rolling ball elements in the built up component systems and a Teflon<sup>®</sup> based composite, FrelonGOLD<sup>®</sup> in the two-piece Uni-Guide system.

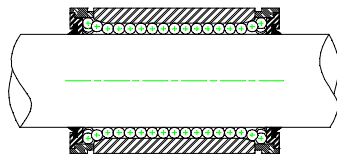

*Recirculating rolling ball element bearings that require seals and metal-to-metal contact with the shaft and raceways*

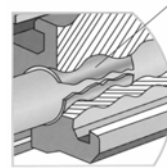

*FrelonGOLD self-lubricating bearing material is molecularly bonded directly to the carriage*

Rolling ball element linear bearings provide low friction upon initial installation, usually in the range of .05 COF (coefficient of friction). If maintained and lubricated properly, they will hold close to that friction over the entire life of the bearings. However, this low coefficient of friction does not translate into consistent motion. Each linear bearing contains upwards of 40 hardened steel balls that continuously move in and out of the load zone while counter rotating, and banging against each other, the raceways, the shafting, and the ends of the bearing. Each movement provides the potential for stick-slip, galling, and vibrations that are fed back through the entire system. Vibrations are magnified by the metal-to-metal contact of each ball with the shaft. Add to that the high susceptibility for damage to the individual balls from shock loads (intentional or inadvertent), corrosive wear, or foreign particulate. Flat spots, skidding, and galling all increase the inconsistency of smooth motion.

The Teflon based composite FrelonGOLD is bonded to the carriage at the molecular level, resulting in a bearing and carriage that have no internal moving elements. Because it is Teflon based, it is a relatively soft material that eliminates all metal-to-metal contact. That same characteristic allows it to handle foreign particulates well. Any that migrate into the bearing are embedded into the material without damage to the bearing or raceway. The coefficient of friction is higher at .125 COF, but the material properties remain consistent for the life of the bearing, resulting in repeatable performance.

<sup>®</sup>Teflon is a registered trademark of DuPont Corp.

## **- Summary**

Imaging, scanning, printing, and output applications are among the most sensitive to vibrations and feedback. The resulting artifact lines can have costly and even devastating results. Therefore the primary need for these systems is a linear guidance system that provides consistent repeatable performance.

The analyzed conclusion is that the Uni-Guide from PBC Linear provides the most consistent results of the motion system choices available. The one-piece rails have an inherent accuracy built into the design and manufacturing process that cannot be duplicated with the built-up components of traditional dual rail systems. The FrelonGOLD bearing material not only eliminates vibration and feedback by eliminating all metal-to-metal contact, but it also provides consistent frictional characteristics for the life of the slide. There are no variations in drive torque from the bearings.

The ultimate result is a predictable quality image output without distracting artifact lines. The repeatability of the mechanical components allows the user to focus on their specialty in the imaging realm with confidence.



**LINEAR MOTION SOLUTIONS**

6402 E. Rockton Road  
Roscoe, IL 61073, USA

(800) 962-8979 • [www.pbclinear.com](http://www.pbclinear.com)